

Dual coil domestic hot water storage tank  
79 and 119 USG / 300 and 450 ltr capacity

# Technical Data Manual

Model Nos. and pricing: see Price List

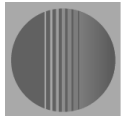

Product may not be exactly as shown

## Vitocell 300-B

### EVB Series

Vertical indirect-fired domestic hot water storage tank  
of high-grade stainless steel with two coils

One heat exchanger coil facilitates heat transfer from the solar collectors to domestic hot water, a second heat exchanger coil allows reheating of the water content by the hot water heating boiler.



*This tank version is not suitable  
for steam heating applications.*



### Product Information

Domestic hot water storage tank of high-grade stainless steel highly effective all-around thermal insulation.

Fully hygienic, efficient and economical domestic hot water production by solar collectors and a hot water heating boiler. Heat from the solar collectors is transferred to the domestic hot water via the lower tank coil.

#### Benefits at a glance:

- Corrosion-resistant tank of **high-grade SA 240-316 Ti stainless steel** offers a long service life.
- Fully hygienic due to **high quality homogeneous stainless steel surfaces**.
- The high-alloy material is immune to cracking or peeling. The tank stays hygienic and requires only minimum service.
- **Does not require a consumable anode** for corrosion protection.
- The entire water content is heated by a **1 1/4" / 25 mm diameter stainless steel heat exchanger surface which extends to the bottom of the tank**.
- Large heat exchanger surfaces allow fast and even heating of the entire water content, guaranteeing a high level of domestic hot water comfort.
- **Standby losses minimized** by highly effective HCFC-free insulation.  
79 USG / 300 ltr version comes equipped with hard PUR foam.  
119 USG / 450 ltr version is supplied with removable soft PET insulation for easier handling.
- **Two thermometers** to show the DHW temperature at the top of the tank, and at the midpoint of the tank.
- **Tank design** is accepted in the State of Massachusetts as being ASME equivalent.
- **Certified to CSA Low Lead Content Certification Program; including US Safe Drinking Water Act, NSF/ANSI 372 as well as other applicable US State requirements.**

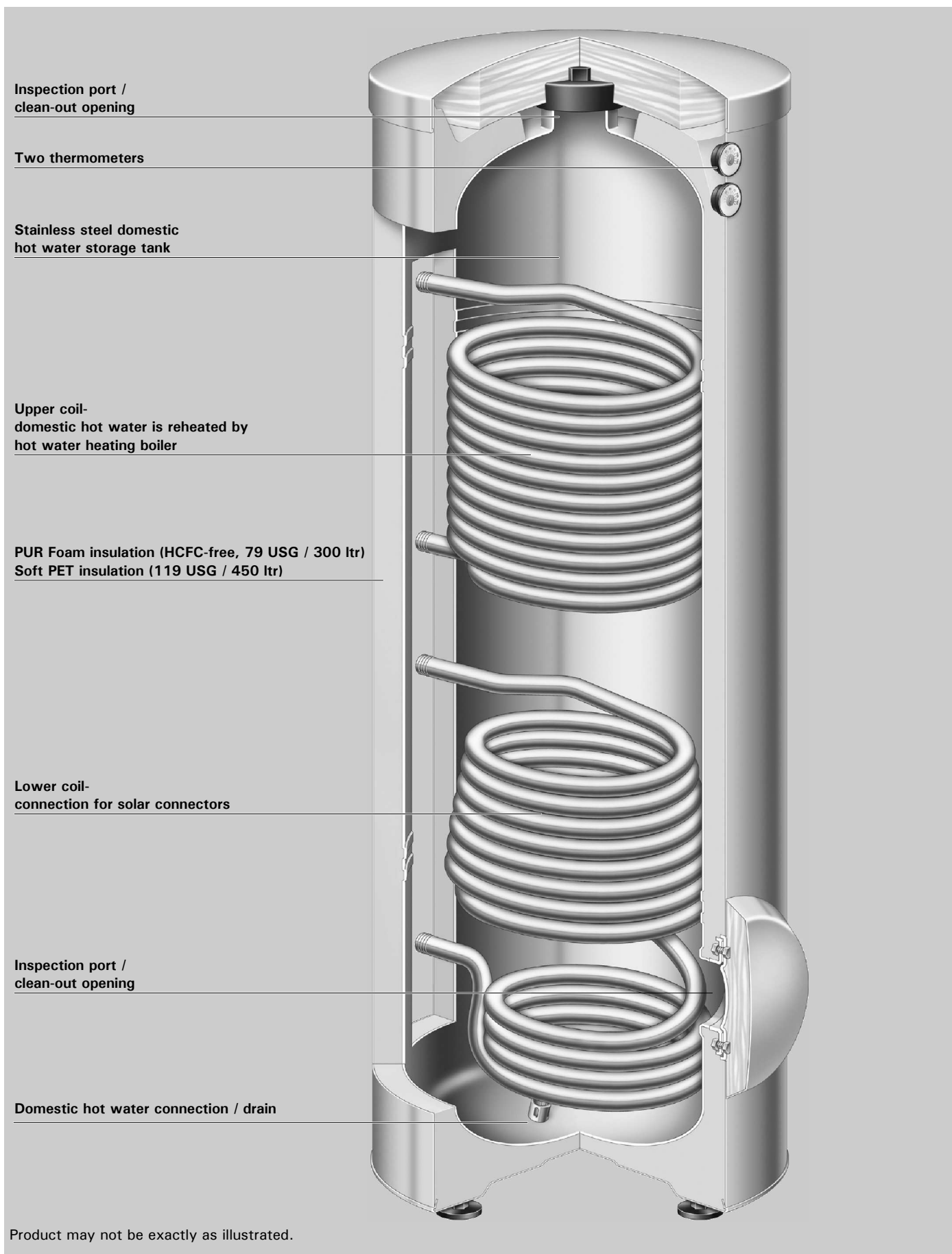

Inspection port /  
clean-out opening

Two thermometers

Stainless steel domestic  
hot water storage tank

Upper coil-  
domestic hot water is reheated by  
hot water heating boiler

PUR Foam insulation (HCFC-free, 79 USG / 300 ltr)  
Soft PET insulation (119 USG / 450 ltr)

Lower coil-  
connection for solar connectors

Inspection port /  
clean-out opening

Domestic hot water connection / drain

5167 415 - 01

Product may not be exactly as illustrated.

## Technical Data

### Technical Data

For DHW production in conjunction with solar systems and heating boilers, and heating systems without low limit for dual coil operation

Suitable for heating systems with:

- max. working pressure on **heat exchanger** side up to **220 psig** at 392°F/200°C
- max. working pressure on **DHW water side** of up to **150 psig** at 210°F/99°C
- max. testing pressure on **DHW side** of **300 psig**

Storage capacity		USG / ltr	79 / 300		119 / 450	
Coil			upper *1	lower *2	upper *1	lower *2
<b>Recovery rate</b> *3 with a DHW temperature increase from <b>50 to 113 °F/ 10 to 45 °C</b> and a supply water temperature of .....	194°F/90°C	MBH / kW GPH / ltr/h	273 / 80 519 / 1965	318 / 93 604 / 2285	273 / 80 519 / 1965	328 / 96 623 / 2358
	176°F/80°C	MBH / kW GPH / ltr/h	219 / 64 415 / 1572	246 / 72 467 / 1769	218 / 64 415 / 1572	219 / 73 474 / 1793
	158°F/70°C	MBH / kW GPH / ltr/h	154 / 45 292 / 1106	178 / 52 337 / 1277	154 / 45 292 / 1106	191 / 56 364 / 1376
	140°F/60°C	MBH / kW GPH / ltr/h	96 / 28 182 / 688	102 / 30 195 / 737	96 / 28 182 / 688	126 / 37 240 / 909
	122°F/50°C	MBH / kW GPH / ltr/h	51 / 15 97 / 368	51 / 21 97 / 368	51 / 15 97 / 368	61 / 18 117 / 442
<b>Recovery rate</b> *3 with a DHW temperature increase from <b>50 to 140 °F/ 10 to 60 °C</b> and a supply water temperature of .....	194°F/90°C	MBH / kW GPH / ltr/h	253 / 74 336 / 1273	278 / 82 372 / 1410	253 / 74 336 / 1273	276 / 81 368 / 1393
	176°F/80°C	MBH / kW GPH / ltr/h	184 / 54 245 / 929	202 / 59 268 / 1014	184 / 54 245 / 929	212 / 62 282 / 1066
	158°F/70°C	MBH / kW GPH / ltr/h	120 / 35 159 / 602	140 / 41 186 / 705	120 / 35 159 / 602	147 / 43 195 / 739
<b>Insulation</b>			PUR Foam		Soft PET insulation	
<b>Standby losses</b> *4		MBH/24 h	7.2		9.2	
<b>Overall dimensions with insulation</b> *5						
Overall length (∅)		inches	25		36.3	
		mm	633		923	
Overall width		inches	28		38.4	
		mm	704		974	
Overall height		inches	70		68.5	
		mm	1779		1740	
Tilt height including insulation		inches	72		65.6	
		mm	1821		1690	
<b>Weight</b>		lbs	251		275	
Tank with insulation		kg	114		125	
<b>Heat exchanger coil</b>		USG	2.9	2.9	2.9	3.9
		ltr	11	11	11	15
<b>Heat exchanger area</b>		ft. <sup>2</sup>	16.1	16.1	15.6	20.5
		m <sup>2</sup>	1.5	1.5	1.45	1.9
<b>Connections</b>	Coils	∅" (male thread)	1"		1 ¼"	
	Domestic cold/hot water	∅" (male thread)	1"		1 ¼"	
	Recirculation	∅" (male thread)	1"		1 ¼"	

\*1 The upper coil is designated for connection to a hot water heating boiler or a heat pump.

\*2 The lower coil is designated for connection to solar collector panels or heat pumps.

\*3 When planning for the recovery rate as stated or calculated, allow for the corresponding circulation pump.

The stated recovery rate is only achieved when the rated output of the boiler is equal to or greater than that stated under "Recovery rate".

\*4 Measured values are based on a room temperature of 68°F / 20 °C and a domestic hot water temperature of 149°F / 65 °C and can vary by 5%.

\*5 For other dimensions, see illustrations and tables on pages 5 and 6.

► For information regarding other Viessmann System Technology componentry, please reference documentation of the respective product.

5167 415 - 01

79 USG / 300 ltr Tank

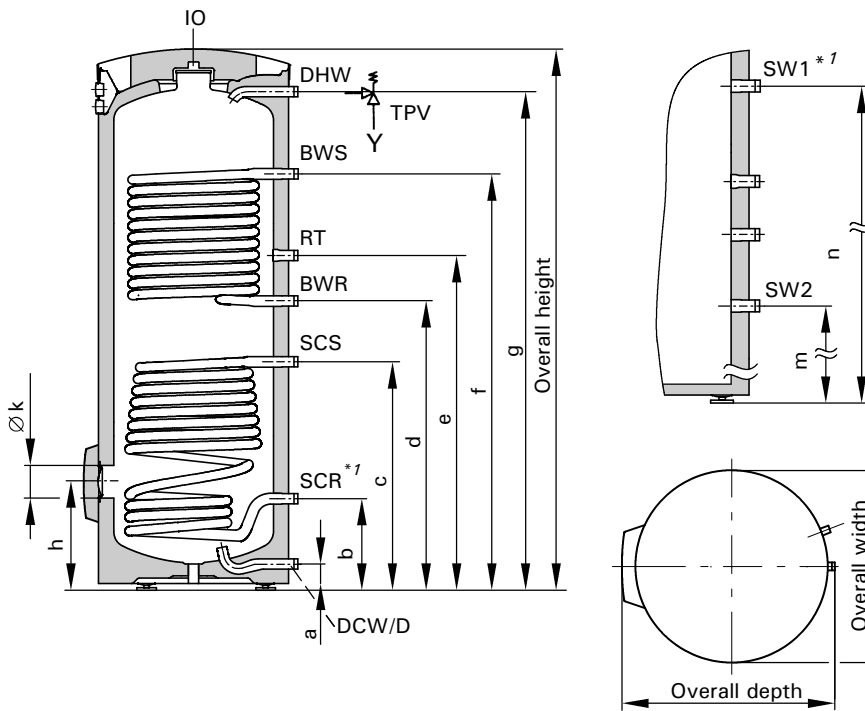

Legend

- IO Inspection and clean-out opening
- D Drain
- BWR Boiler water return (upper coil)
- SCR Solar collector return (lower coil) or boiler return
- BWS Boiler water supply (upper coil)
- SCS Solar collector supply (lower coil) or boiler supply
- DCW Domestic cold water
- SW1 Sensor well opening for DHW tank temperature sensor or boiler controller aquastat (located at the same height as BWS (79 USG / 300 ltr only), rotated 20°)
- SW2 Sensor well for lower thermometer at SCS level
- DHW Domestic hot water
- RT Recirculation tapping
- TPV Temperature and pressure relief valve

*\*1For solar heating systems Viessmann recommends placement of the DHW tank temperature sensor in the solar collector return (SCR). This requires a brass elbow with sensor well (accessory - Part No. 7175 213). The DHW tank temperature sensor of the boiler control is placed in SW1.*

DHW tank temperature sensor in solar heating applications  
79 USG / 300 ltr

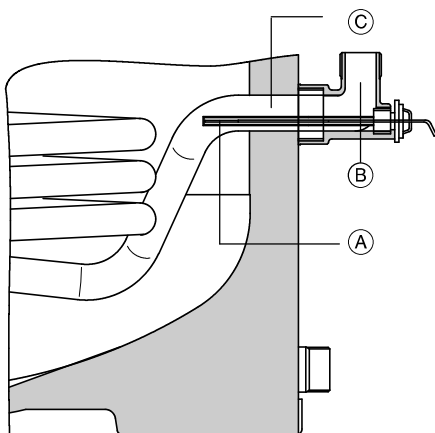

- (A) DHW tank temperature sensor for solar application (included with solar control unit)
- (B) Brass elbow with sensor well
- (C) Solar collector return connection

Dimensions

Storage capacity	USG / ltr	79 / 300
a	inches	3½
	mm	87
b	inches	11¾
	mm	301
c	inches	29⅔
	mm	751
d	inches	37½
	mm	951
e	inches	43⅓
	mm	1101
f	inches	54
	mm	1369
g	inches	64⅔
	mm	1640
h	inches	14
	mm	357
k	inches	4
	mm	100
m	inches	29½
	mm	751
n	inches	54
	mm	1369

# Technical Data

## 119 USG / 450 ltr Tank

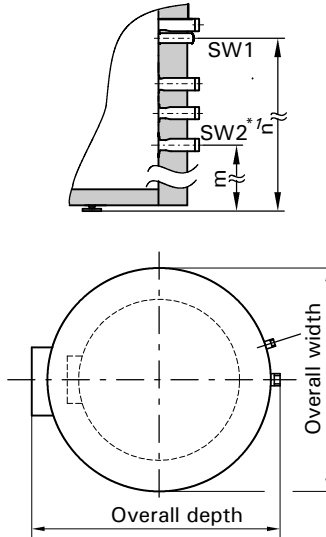
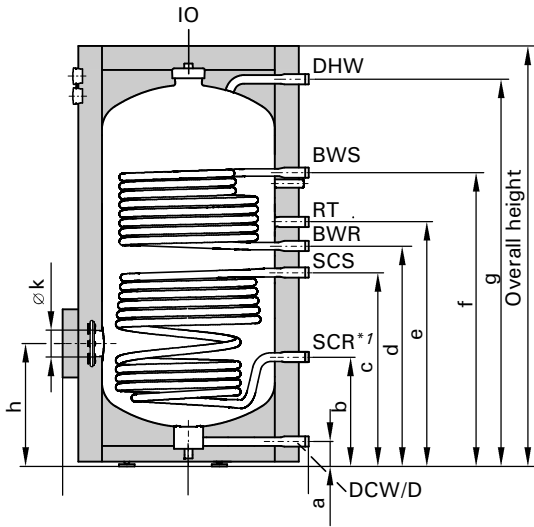

### Legend

- IO Inspection and clean-out opening
- D Drain
- BWR Boiler water return (upper coil)
- SCR Solar collector return (lower coil) or boiler return
- BWS Boiler water supply (upper coil)
- SCS Solar collector supply (lower coil) or boiler supply
- DCW Domestic cold water
- SW1 Sensor well opening for DHW tank temperature sensor or boiler controller aquastat
- SW2 Sensor well for lower thermometer at SCS level
- DHW Domestic hot water
- RT Recirculation tapping
- TPV Temperature and pressure relief valve

*\*1For solar heating systems Viessmann recommends placement of the DHW tank temperature sensor in the solar collector return (SCR). This requires a brass elbow with sensor well (accessory - Part No. 7219 729). The DHW tank temperature sensor of the boiler control is placed in SW1.*

### DHW tank temperature sensor in solar heating applications 119 USG / 450 ltr

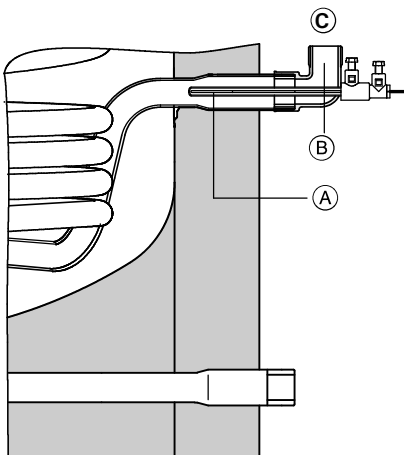

- (A) DHW tank temperature sensor for solar application (included with solar control unit)
- (B) Brass elbow with sensor well
- (C) Solar collector return connection

### Dimensions

Storage capacity	USG / ltr	119 / 450
a	inches	4 <sup>1</sup> / <sub>16</sub>
	mm	103
b	inches	17 <sup>7</sup> / <sub>8</sub>
	mm	453
c	inches	31 ½
	mm	802
d	inches	36
	mm	912
e	inches	39 <sup>7</sup> / <sub>8</sub>
	mm	1012
f	inches	47 <sup>7</sup> / <sub>8</sub>
	mm	1216
g	inches	63
	mm	1601
h	inches	20
	mm	508
k	inches	4
	mm	100
m	inches	31 ½
	mm	802
n	inches	46
	mm	1170

**Pressure drop on heating water side**  
of a single coil

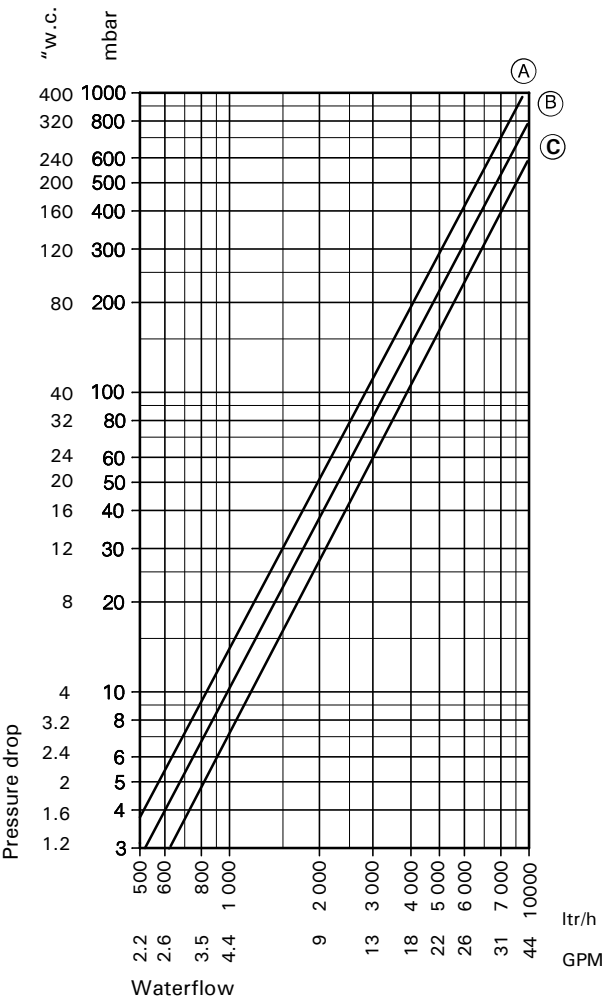

**Domestic hot water pressure drop**

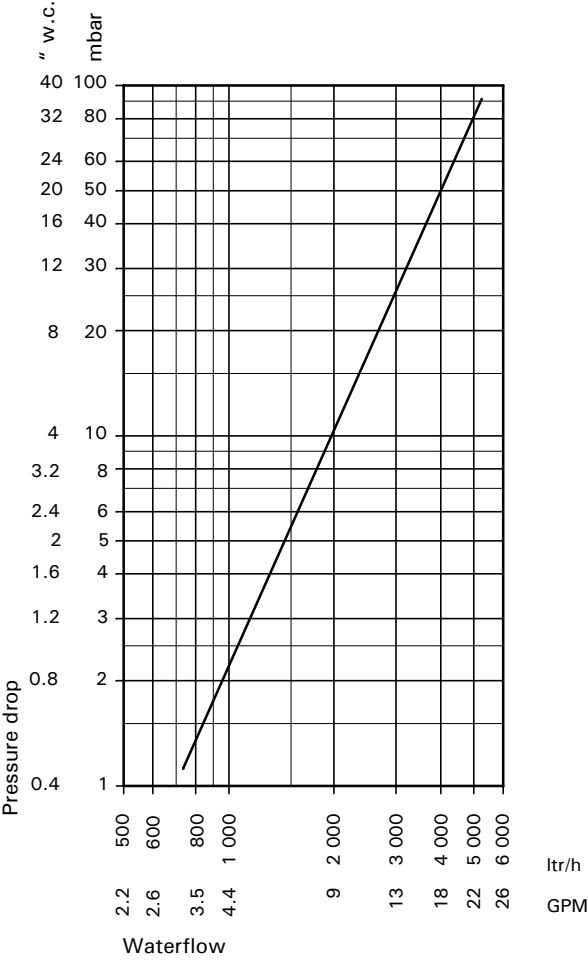

- (A) Lower indirect coil, 119 USG / 450 ltr capacity
- (B) Lower indirect coil, 79 USG / 300 ltr capacity
- (C) Upper indirect coil, 79 USG / 300 ltr and 119 USG / 450 ltr capacity

**Domestic hot water draw rate**

Storage tank contents heated to 140°F / 60°C, boiler not reheating

<b>Storage capacity</b>	USG	79	119
	ltr	300	450
<b>Domestic hot water draw</b>	USG	34	62
Water with t = 140°F / 60°C (constant)	ltr	128	233
<b>Percentage tank volume</b>		42%	52%

5167 415 - 01

## Standard Equipment

### 79 USG / 300 ltr capacity DHW Tank

DHW tank made from high-alloy stainless steel with fitted PUR hard foam thermal insulation.

- 2 thermometers °F / °C
- adjustable leveling bolts

The following are packed separately and attached to the crate:

- 1 Loctite package
- 1 temperature and pressure relief valve
- 2 reduction couplings (1"x½")
- 2 sensor wells
- 2 insulation blankets for sensor wells
- 7 brass adaptors (1")
- 1 brass tee (1")
- 1 brass hex bushing (1"x¾")
- 1 brass cap (1")

Must be ordered separately:

- 1 brass elbow with sensor well for solar collector return, Part No. 7175 213

### 119 USG / 450 ltr capacity DHW Tank

DHW tank made from high alloy stainless steel and separately packed soft PET thermal insulation.

- 2 thermometers °F / °C
- adjustable leveling bolts

The following are packed separately and attached to the crate:

- 1 Loctite package
- 1 temperature and pressure relief valve
- 2 reduction couplings (1"x½")
- 2 sensor wells
- 2 insulation blankets for sensor wells
- 7 brass adaptors (1 ¼")
- 1 brass tee (1 ¼")
- 1 brass hex bushing (1 ¼"x¾")
- 1 brass cap (1 ¼")

Must be ordered separately:

- 1 brass elbow with sensor well for solar collector return, Part No. 7219 729

## Product Installation

### Domestic hot water connection

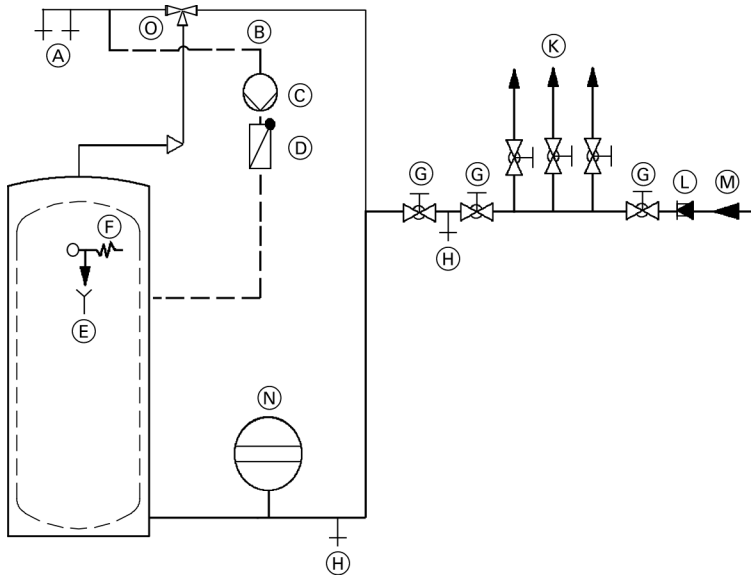

- (A) Domestic hot water supply
- (B) DHW recirculation line
- (C) DHW recirculation pump
- (D) Spring-loaded flow check valve
- (E) Discharge pipe
- (F) Pressure and temperature relief valve
- (G) Shut-off valve
- (H) Drain
- (K) Domestic cold water supply lines
- (L) Backflow preventer
- (M) Domestic cold water inlet
- (N) Precharged expansion tank  
(required where backflow preventer is installed; check local plumbing codes and requirements)
- (O) Thermostatic mixing valve/anti-scald valve for solar applications (field supply)

### **WARNING**

Due to the potentially high DHW temperatures generated by the solar heating system, the domestic hot water temperature must be limited to a maximum of 140°F/60°C by installing a mixing device, e.g. a thermostatic mixing valve. The mixing device does not completely eliminate the risk of scalding at the tap. The installation of a mixing tap is required.



Installation Example

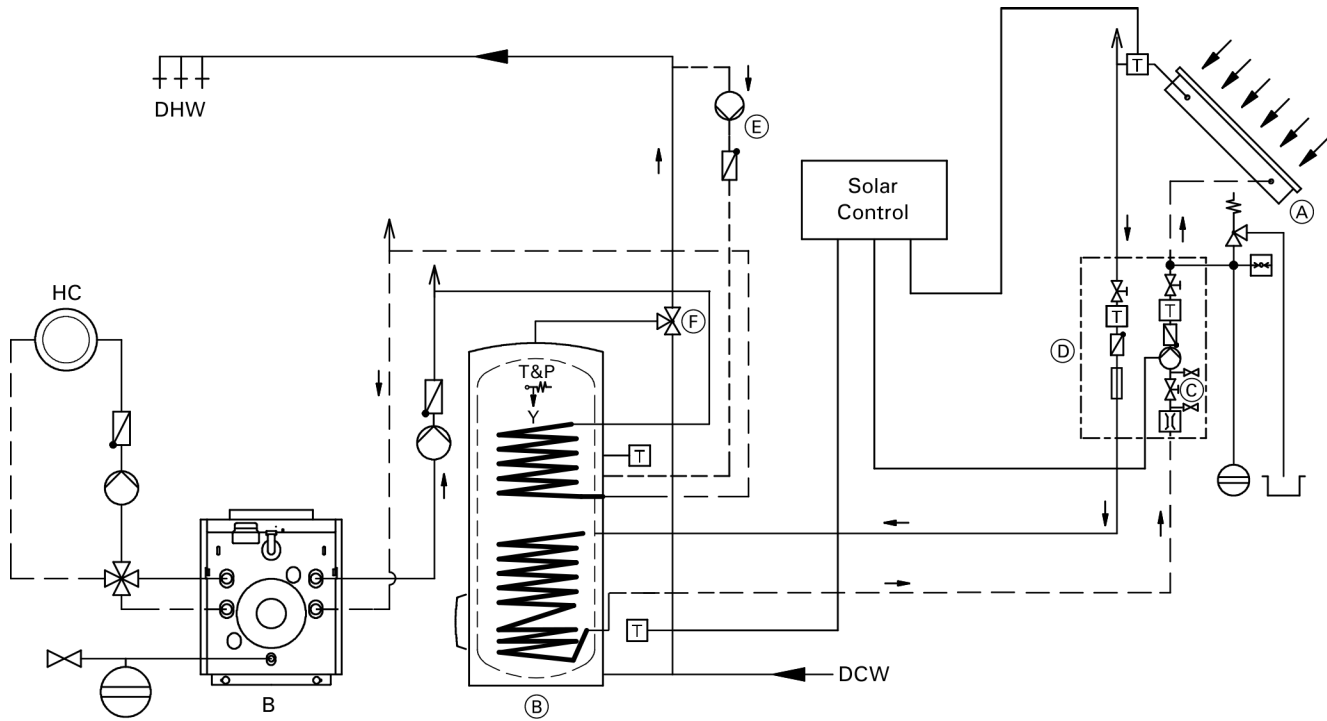

- (A) Solar collector
- (B) Vitocell 100-B
- (C) Filling valve
- (D) Solar-Divicon (pumping station)
- (E) Recirculation pump
- (F) Anti-scald tempering valve

- HC Heating circuit
- B Oil/Gas-fired boiler
- DCW Domestic cold water
- DHW Domestic hot water
- T&P Temperature and pressure relief valve

# System Design Guidelines

## Sensor well

The supplied stainless steel sensor wells are to be used for control sensors to ensure maximum operational safety. The top sensor well is used for the DHW sensor connected to the boiler control.

Should the supplied sensors not fit into the sensor wells, other stainless steel sensor wells must be used.

For solar heating systems, Viessmann recommends placement of the DHW tank temperature sensor in the solar collector return. This requires a brass elbow with sensor well included in the accessory pack (see pg. 8).

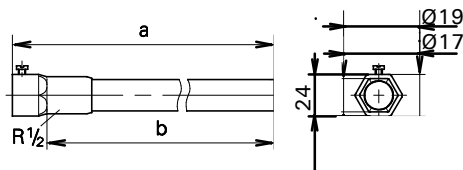

Dimensions	USG / capacity	79 / 300	120 / 450
a	inches	8.7	13
	mm	220	330
b	inches	7.9	12 ¼
	mm	200	310

**! WARNING**

To ensure optimum, safe operation, the supplied stainless steel well must be installed. The well diameter is large enough to accommodate a wide variety of sensing bulbs.

Always use spring clip to ensure proper contact of capillary bulb against the stainless steel well for proper sensing/heat transfer!

## Heating water supply temperature over 230°F / 110°C

These operating conditions require the installation of an additional safety high limit into the DHW storage tank, preventing the temperature from rising above 203°F / 95°C. A domestic hot water tempering valve must be used.

## Temperature and pressure relief valve

A temperature and pressure relief valve (T&P relief valve) is supplied with the tank. The heating contractor must install the valve on each tank in a method meeting code requirements. If local codes require a different relief valve, substitute the manufacturer's supplied valve. The tank is approved for 100 psig where a CRN is required. Maximum operating pressure is 150 psig.

The T&P relief valve supplied with the tank is tested under ANSI Z21.22 Code for Relief Valves and Automatic Gas Shut-off Devices for Hot Water Supply Systems.

## Backflow preventers

Where backflow preventers are required, a domestic water expansion tank installation is recommended in the cold water inlet piping before the cold water enters the Vitocell. For the backflow device, observe local plumbing codes and regulations.

Watts Model 40XL-8	100 psig (Canada where CRN is required)	150 psig (US and Canada)
ASME pressure steam rating	998 MBH	1438 MBH
CSA temperature steam rating	205 MBH	
Relief temperature	210°F (99°C)	
Inlet thread	¾" male	
Outlet thread	¾" female	

## Warranty excerpt

Our warranty for domestic hot water tanks states that the water to be heated must be of drinking (potable) water quality and that any water treatment equipment in use must function correctly.

Viessmann accepts no responsibility for damage howsoever caused and reserves the right to withdraw the product warranty if the product has been improperly installed or misapplied by the installer, contractor or final user. In order to qualify for product warranty, strict adherence to the installation and service manuals must be assured. In the event that Viessmann non-approved components are utilized, Viessmann reserves the right to withdraw all expressed or implied warranties without written notice.

The water to be heated with the Vitocell must be drinking (potable) water quality. If the tank is used to heat other media, the warranty will be null and void. Damage resulting from excessive pressure or temperature is clearly not the responsibility of Viessmann.

The amount of chloride and sulfate acceptable to the tank is limited. In areas where high concentrations of chloride and sulfate are present in drinking water, please consult Viessmann for directions.

For full warranty details, please read the product warranty card.



---

Viessmann Manufacturing Company Inc.  
750 McMurray Road  
Waterloo, Ontario • N2V 2G5 • Canada  
**TechInfo Line 1-888-484-8643**  
1-800-387-7373 • Fax (519) 885-0887  
www.viessmann.ca • info@viessmann.ca

Viessmann Manufacturing Company (U.S.) Inc.  
45 Access Road  
Warwick, Rhode Island • 02886 • USA  
**TechInfo Line 1-888-484-8643**  
1-800-288-0667 • Fax (401) 732-0590  
www.viessmann-us.com • info@viessmann-us.com

Printed on environmentally friendly  
(recycled and recyclable) paper.



Technical information subject to change without notice.

5167 415 - 01